



HAYTER

MAKERS OF THE FINEST MOWERS

Parts Catalogue

R53A Recycling Mower

Code 449E

Serial No. 290000001

Manual Part No. 111-2845 Rev A

Contents

Description	Page	Description	Page
Housing Component Assembly 3	Lower Handle Assembly 6
Rear Wheel, Transmission and Side Discharge Chute Assembly 4	Blade and Engine Assembly 7
Upper Handle Assembly 5	Electrical Assembly 8
		Bag Assembly 9

Part Description Abbreviations

Part descriptions in this catalog may include the following abbreviations.

AR. as required	HYD. hydraulic
ASM. assembly	LH. left hand
BBC. blade brake clutch	NI. nylon insert
CARR. carriage	NPTF. national pipe thread fine
DEG. degrees	PFH. phillips flat head
EXT. external	PPH. phillips pan head
FH. flat head	PPHTF. phillips pan head thread forming
GA. gauge	PRH. phillips round head
HD. heavy-duty	PTH. phillips truss head
HF. hex flange	PTO. power-take-off
HH. hex head	RH. right hand
HHF. hex head flange	ROPS. roll-over protection system
HHFTF. hex head flange thread forming	SFH. slotted fillister head
HJ. hex jam	SHH. slotted hex head
HLH. hex lag head	SHWH. slotted hex washer head
HOC. height-of-cut	SPH. slotted pan head
HSBH. hex socket button head	SQH. square head
HSFH. hex socket flat head	SRH. slotted round head
HSH. hex socket head	STD. standard
HWH. hex washer head	TAP. self tapping
HWHTF. hex washer head thread forming	TTH. torx truss head

Footnotes

- ❶ Not illustrated
- ❷ Not serviced separately
- ❸ Obtain from your local Briggs & Stratton dealer

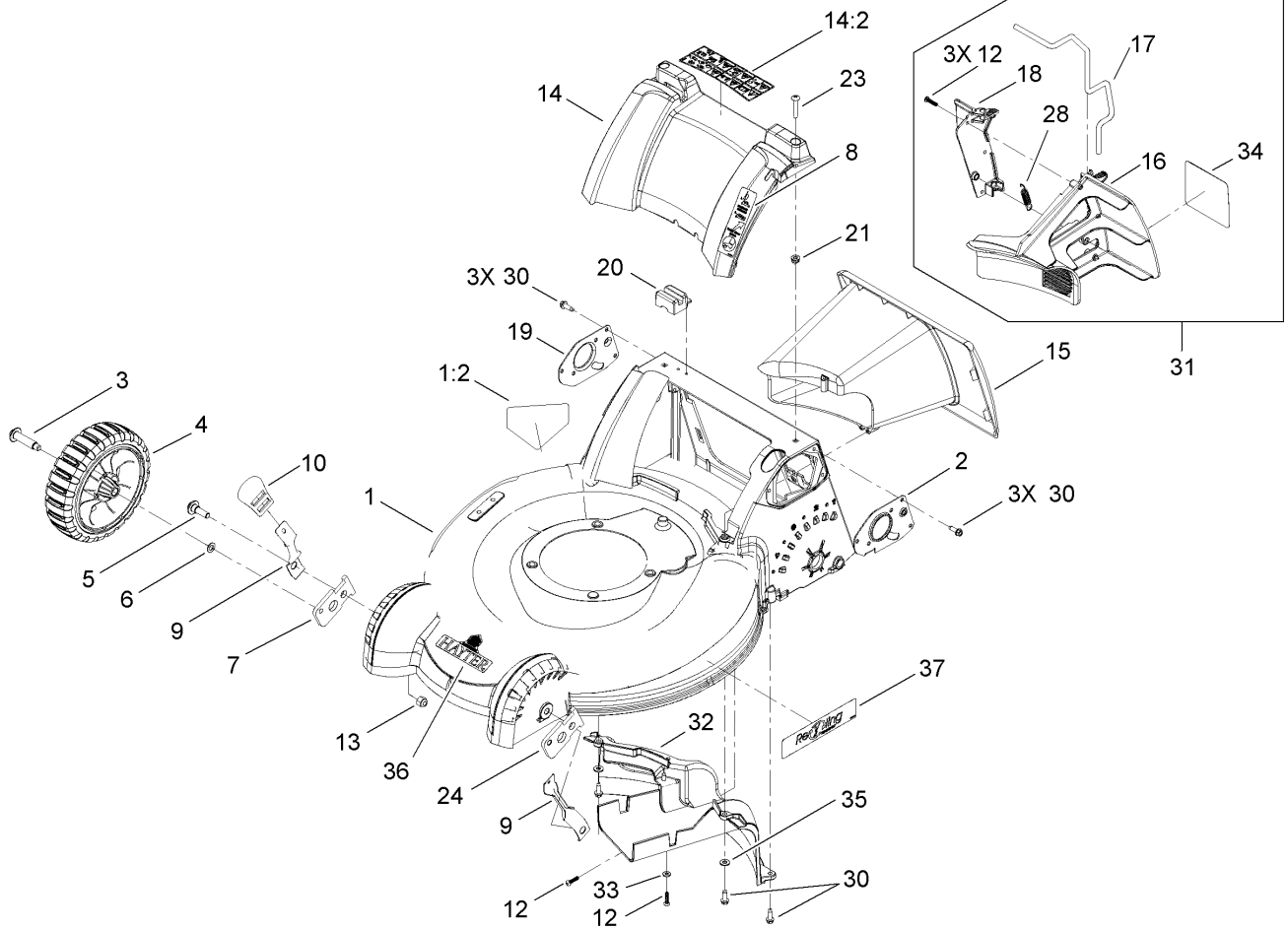

Housing Component Assembly

Ref	Part No.	Qty.	Description
1	117-4111	1	Housing ASM
1:2	112-8760	1	Decal-Danger
2	110-9415-03	1	Mount-Handle, LH
3	614650	2	Bolt-Shoulder
4	117-4103	2	8 Inch Wheel ASM
5	614672	2	Bolt-Shoulder
6	40-1940	2	Washer
7	110-9421	1	Arm-Pivot, RH
8	111-2210	1	Decal-Handle Adjust, Hayter
9	110-9434	2	Arm-Spring, Front
10	110-7125	2	Knob-HOC
12	108-7476	6	Screw-Plastite
13	3296-39	2	Nut-Lock, NI
14	115-3177	1	Cover-Rear
14:2	114-2820	1	Decal-Warning
15	110-9456	1	Tunnel
16	110-9446	1	Plug-Mulch, LH
17	110-9448	1	Latch-Plug, Mulch
18	110-9447	1	Plug-Mulch, RH
19	110-9416-03	1	Mount-Handle, RH
20	110-1787	1	Module-Switch
21	94-1610	2	Nut-Clip
23	108-0965	2	Screw-PTH
24	110-9420	1	Arm-Pivot, LH

Ref	Part No.	Qty.	Description
28	110-9458	1	Spring-Extension
30	49-2040	11	Screw-HWHTF
31	110-9468	1	Mulch Plug ASM
32	110-9413	1	Baffle-Rear
33	3256-14	1	Washer-Flat
34	110-9457	1	Decal-Plug, Mulch
35	3256-22	2	Washer-Flat
36	410087	1	Decal-Hayter
37	114-3233	1	Decal-Recycling

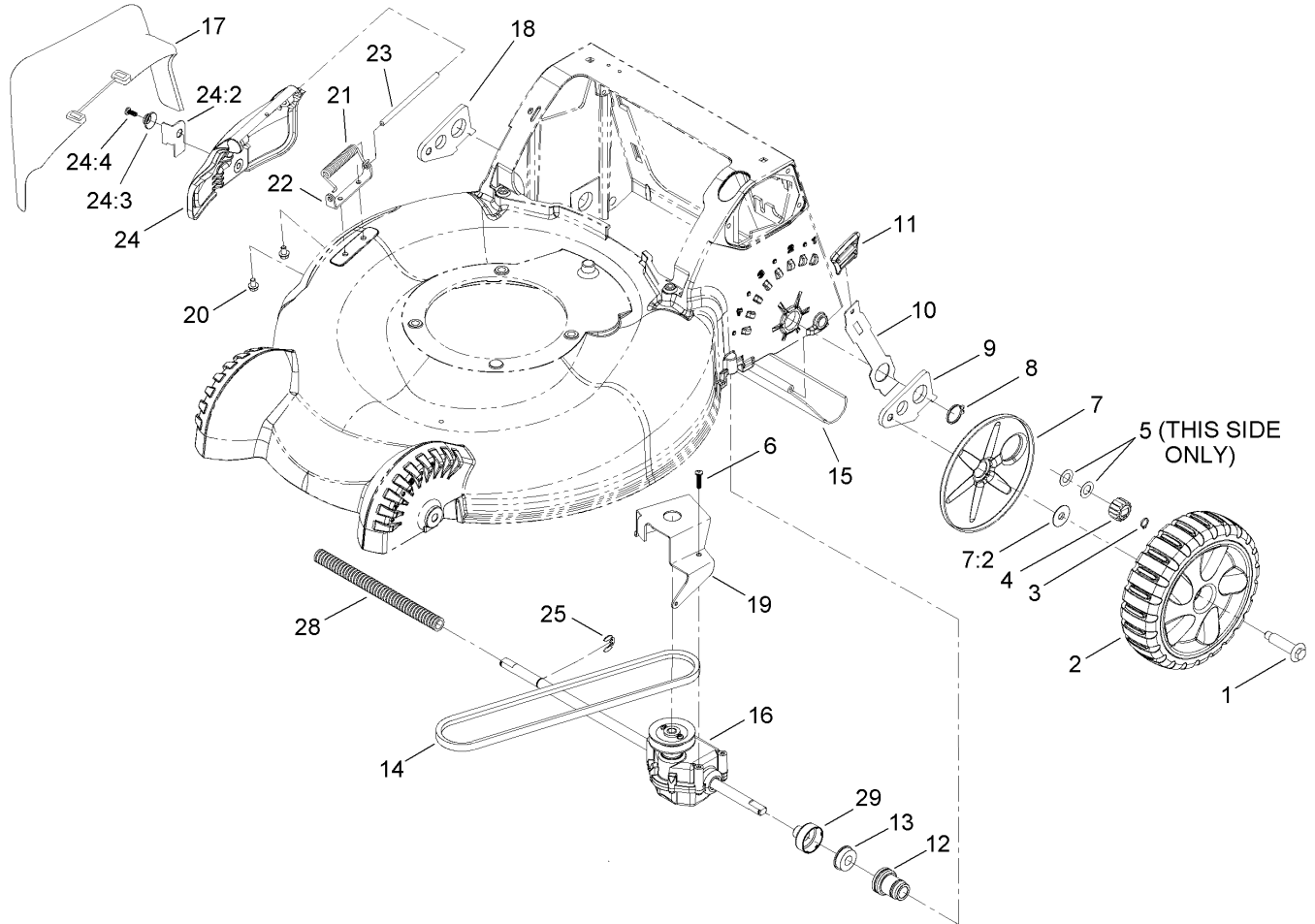

Rear Wheel, Transmission and Side Discharge Chute Assembly

Ref	Part No.	Qty.	Description
1	614650	2	Bolt-Shoulder
2	117-4104	2	Rear Wheel ASM
3	32151-61	2	Ring-Retaining
4	110-9417	2	Pinion
5	36-4780	2	Washer-Plain
6	108-7476	3	Screw-Plastite
7	117-4197	2	Cover-Wheel, ASM
7:2	614426	1	Washer-Stepped
8	32151-36	2	Ring-Retaining
9	108-9344	1	Arm-Rear Pivot, LH
10	110-9445	2	Arm-Spring, Rear
11	110-7125	2	Knob-HOC
12	110-9422	2	Retainer-Bearing
13	104-8699	2	Bearing-Ball
14	110-9429	1	V-Belt
15	112-8768	1	Shield-Trailing
16	114-2812	1	Transmission ASM
17	105-3028	1	Chute-Discharge, Side
18	108-9343	1	Arm-Rear Pivot, RH
19	114-7977-03	1	Bracket-Transmission
20	99-8445	2	Screw-HWH
21	99-5293	1	Spring-Torsion
22	112-6416	1	Bracket-Cover
23	99-5291	1	Rod-Cover

Ref	Part No.	Qty.	Description
24	106-8376	1	Discharge Door ASM
24:2	107-0795	1	Latch-Door
24:3	107-7456	1	Cap-Door
24:4	107-7461	1	Screw-Plastite
25	65-2720	1	Ring-Clip, Locking
28	24-7922	1	Cover-Shaft, Drive
29	114-2755	2	Cap-Bearing

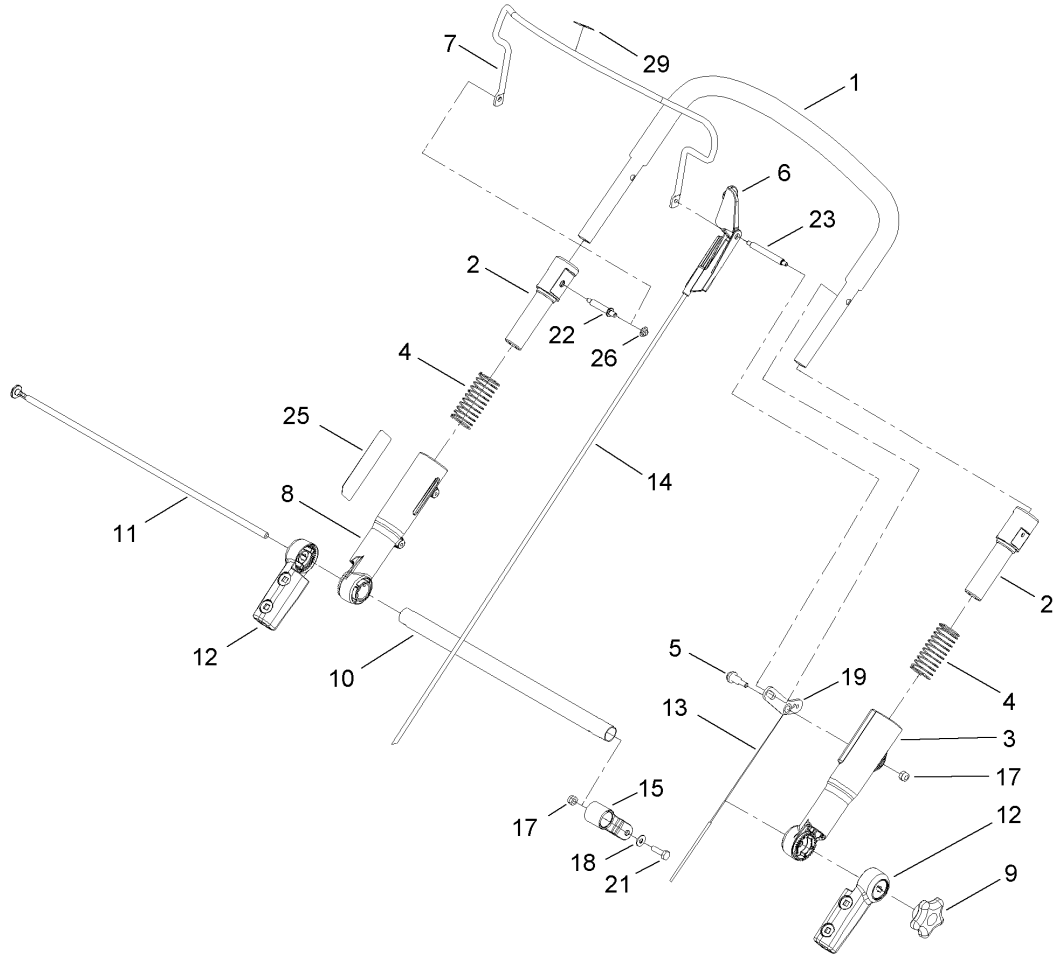

Upper Handle Assembly

Ref	Part No.	Qty.	Description
1	108-0974	1	Upper Handle ASM
2	112-8754	2	Sleeve-Inner
3	112-1544	1	Sleeve-Outer, LH
4	107-3869	2	Spring-Compression
5	104-0858	1	Bolt-Shoulder
6	112-8764	1	Stop-Pivot
7	110-1819-03	1	Bail-Brake
8	112-1545	1	Sleeve-Outer, RH
9	106-4161	1	Knob-Handle
10	107-3867-03	1	Tube-Cross
11	107-3871	1	Rod-Threaded
12	107-3865	2	Mount-Handle, Lower
13	110-9465	1	Cable-Traction
14	107-3903	1	Cable-Brake
15	112-8801	1	Clamp-Cable
17	3296-73	2	Nut-Lock, NI
18	3256-1	1	Washer-Flat
19	107-3893	1	Lever-Traction
21	321-5	1	Screw-HH
22	108-0959	1	Pin-Handle
23	108-1008	1	Pin-Bail, LH
25	111-2209	1	Decal-Sas, Hayter
26	108-9378	1	Retainer-Push On
29	117-4157	1	Decal-Engine Stop

--	--	--	--

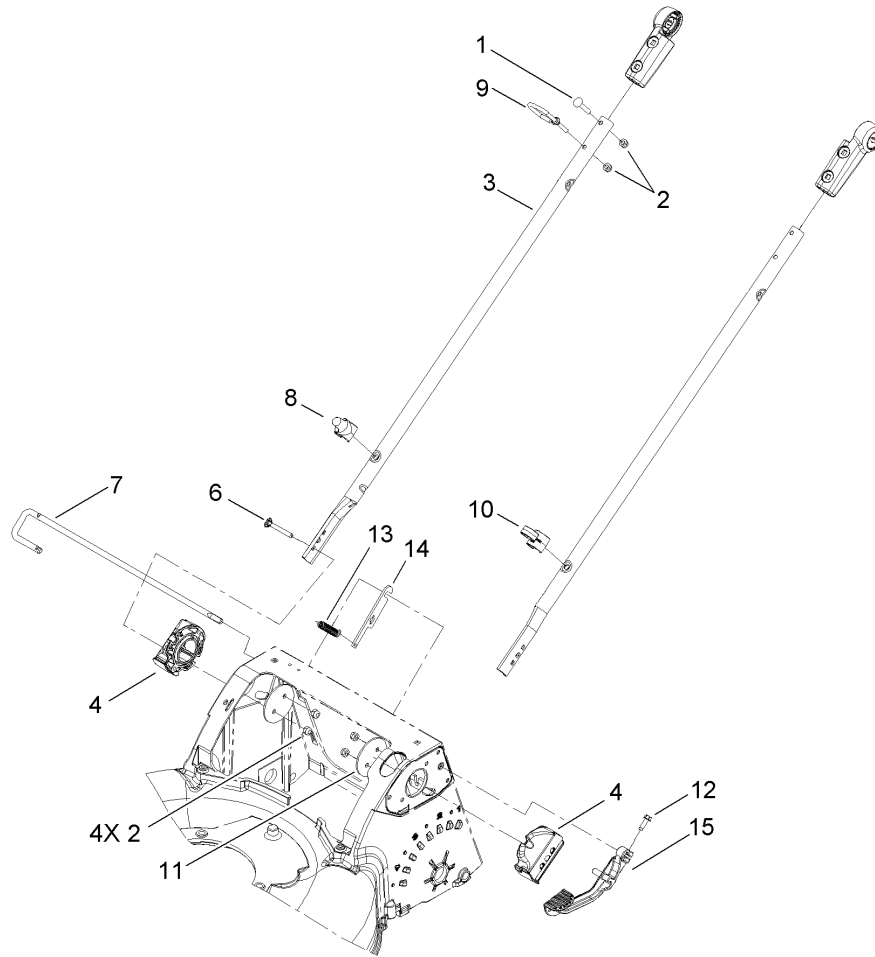

Lower Handle Assembly

Ref	Part No.	Qty.	Description	
1	108-0988	3	Screw-CARR	
2	3296-73	8	Nut-Lock, NI	
3	107-3887-03	2	Tube-Lower	
4	114-2791	2	Mount-Handle, Lower	
6	95-4453	4	Screw	
7	112-8755	1	Rod-Release, Handle	
8	117-4141	1	Guide-Rope, Lower	
9	107-3908	1	Guide-Rope, Upper	
10	106-6805	1	Guide-Cable	
11	107-3944-03	2	Plate	
12	49-2040	1	Screw-HWHTF	
13	112-1542	1	Spring-Extension	
14	112-1539	1	Plate-Rod, Release	
15	110-1823-03	1	Lever-Release	

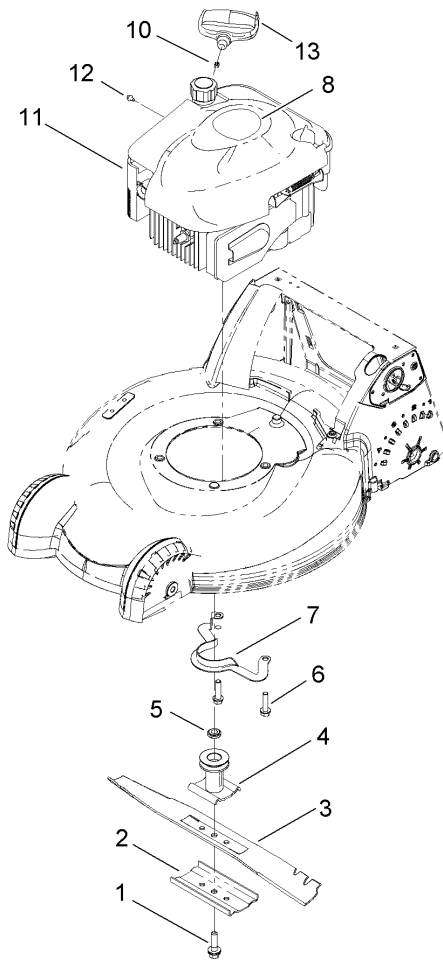

Blade and Engine Assembly

Ref	Part No.	Qty.	Description				
1	105-8579	1	Bolt-Blade				
2	108-3766-03	1	Support-Blade				
3	108-0954-03	1	Blade-21 Inch				
4	106-3987	1	Blade Driver ASM				
5	106-3999	1	Spacer-Driver				
6	32144-102	3	Screw-HWH				
7	108-8110-03	1	Guide-Belt				
8	111-2207	1	Decal				
10	2210-316	1	Stop-Rope				
11		1	Engine-Quantum, 126T05-0239-B1				
12	98-1394	1	Screw-HWH				
13	117-4142	1	Handle-Recoil				

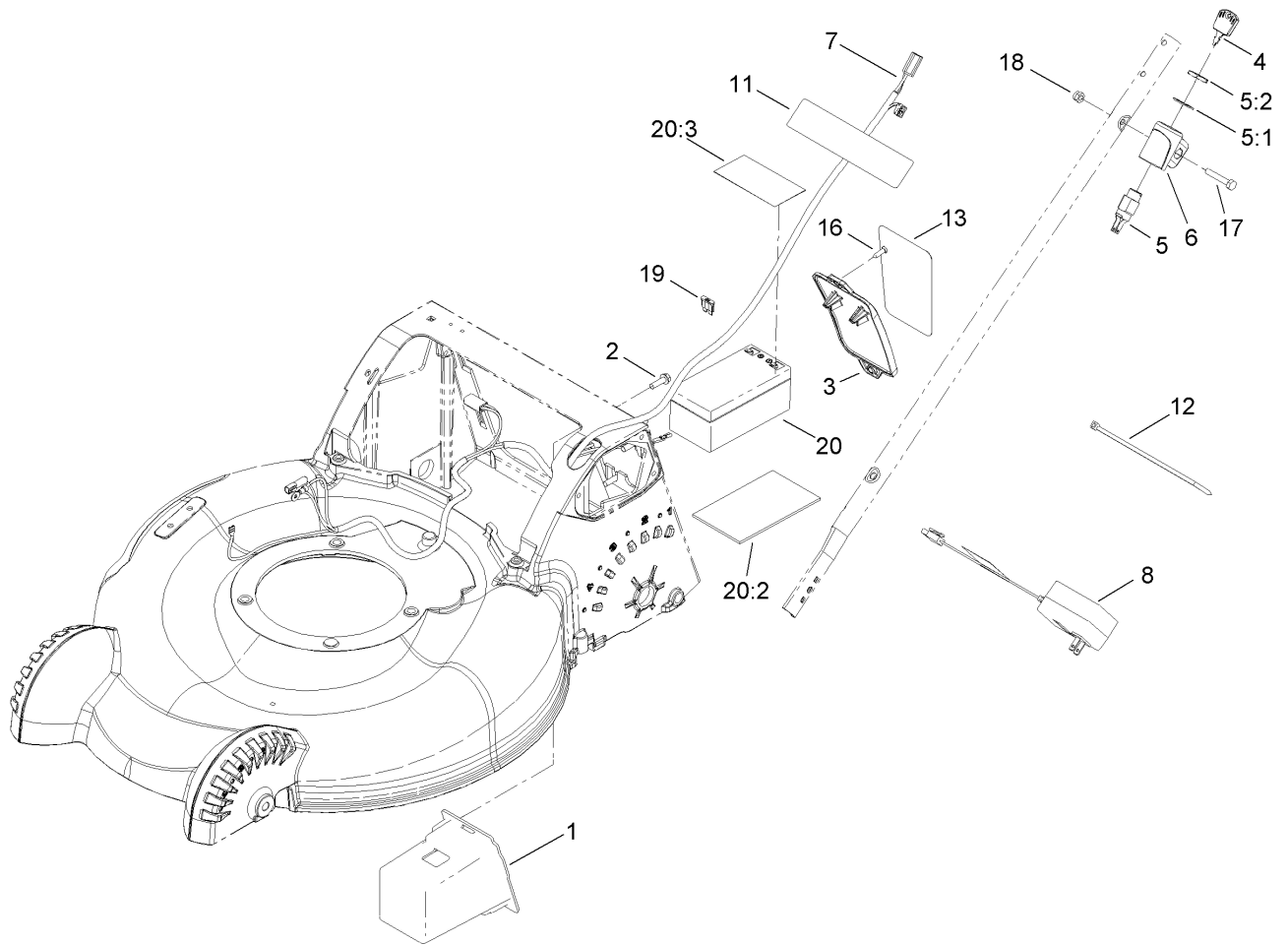

Electrical Assembly

Ref	Part No.	Qty.	Description
1	107-3932	1	Box-Battery
2	46-8091	4	Screw-HWH
3	108-0981	1	Cover-Battery
4	700918	1	Key
5	46-5780	1	Switch-Starter
5:1	3254-5	1	Washer-Tooth
5:2	218-461	1	Nut-HH
6	108-9760	1	Mount-Switch
7	114-2815	1	Harness-Wire
8	117-4108	1	Charger-Hayter
11	104-7953	1	Decal-Harness
12	614249	2	Strap-Tie
13	108-0992	1	Decal-Instruction, Battery
16	32144-111	2	Screw-PPH
17	321-51	1	Screw-HH
18	3296-73	1	Nut-Lock, NI
19	99-6124	1	Fuse-40 Amp
20	108-9358	1	Battery
20:2	108-0987	1	Foam-Battery
20:3	112-8763	1	Decal-Terminal, Battery

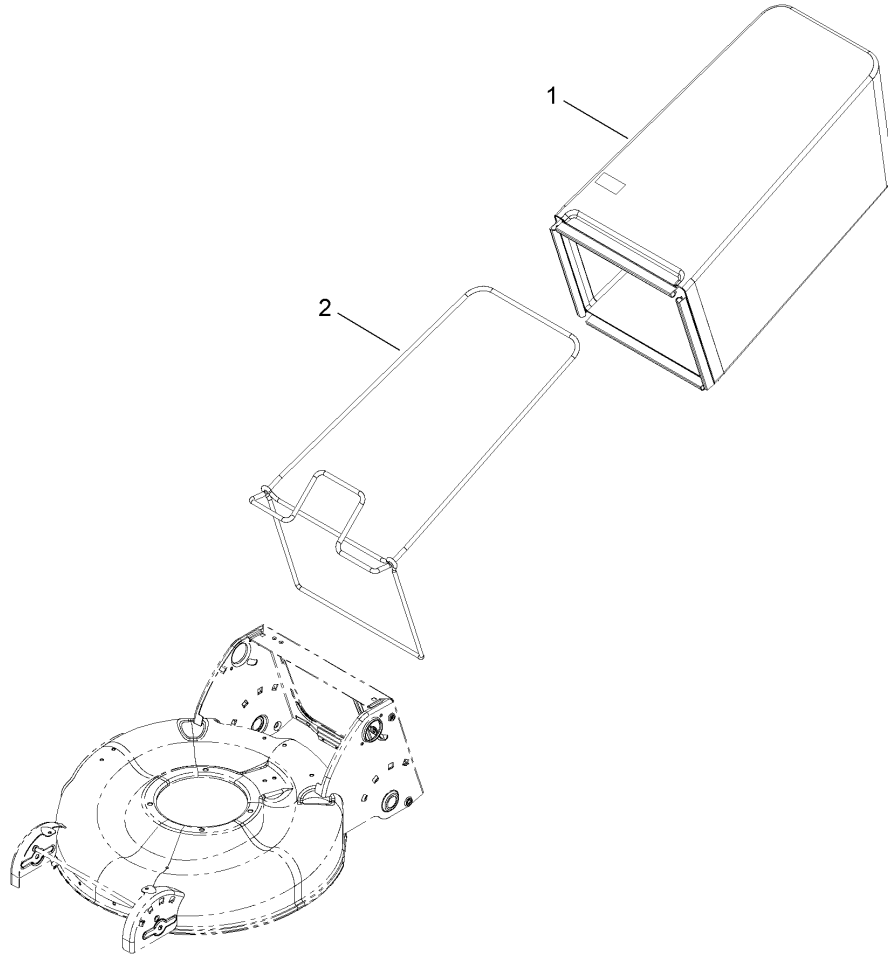

Bag Assembly

Ref	Part No.	Qty.	Description
1	117-4105	1	Grass Bag ASM
2	112-8750-03	1	Frame-Bag

--	--	--	--

NOTES

NOTES

